



BLACK LAB SYSTEM
TECHNICAL NOTE #112

SUBJECT: Connecting 4-20 ma Current Loop Instruments to the Black Lab
See also Bulletin on CIM (Connector Interface Modules) available from Analog Interfaces

DATE OF ISSUE: 09/10/05

REV # 0

4-20 ma Loop Instruments

Many industrial sensors, signal conditioners, and process transmitters operate with what is called a 4–20 milliamp current loop. Some of these sensors are “loop powered” meaning that they derive their electrical energy from the current loop itself. Other instruments require a separate source of power that is independent from the current loop. The current loop type of sensor has the advantage that it can be located a long distance from the data acquisition system without generating much noise in the connecting cable. These sensors should be connected with twisted pair wire or cable ([Belden 8761](#) for example). The following examples show some of the ways to connect these sensors.

Loop Powered (2-wire) Instruments Using External Power Supply

This type of instrument requires an external power supply, typically 24 volts. Any of the Type 1, Type 2 or Type 3 Connector Interface Modules is suitable for this type of connection.

The positive terminal of the power supply is normally connected to the positive (+) terminal of the transmitter or sensor. The negative (–) terminal of the transmitter is connected to the Input Hi terminal of the CIM. A resistor R is connected across the Input Hi to Input Lo terminals to convert the current into a voltage that the Black Lab can measure. The resistor R should be chosen to generate a convenient voltage. A 250 ohm resistor will give a voltage signal of 1 to 5 volts. A 500 ohm resistor will give a voltage signal of 2 to 10 volts. A connection made from the Input Lo terminal of the Black Lab to the negative of the power supply returns the current back to the power supply. Remember that the Input Lo terminal also must be connected to the Analog Ground (AGND) terminal.

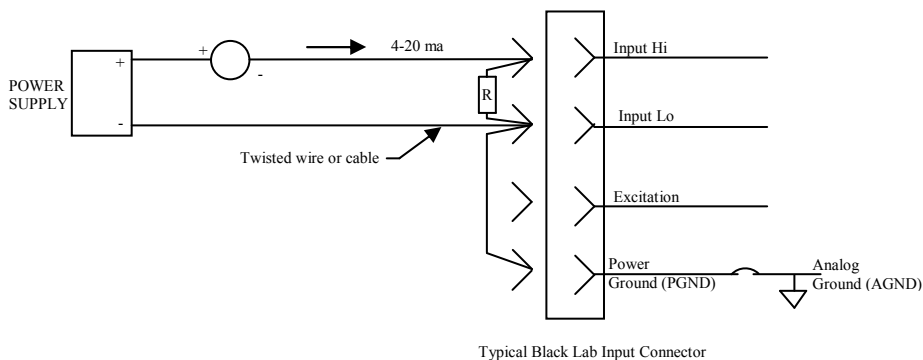

Loop Powered (2-wire) Instruments Using Black Lab Power Supply

In order to connect this type of instrument, the Black Lab must be equipped with the optional 24 volt power supply in the Type III Connector Interface Module. One of the wires to the transmitter connects the Excitation terminal to the positive (+) input of the transmitter. The negative (-) terminal of the transmitter is connected to the Input Hi terminal of the CIM III. A resistor R is connected across the Input Hi to Input Lo terminals to convert the current into a voltage that the Black Lab can measure. A jumper between the Input Lo and the analog common returns the current back to the power supply. The resistor R should be chosen to generate a convenient voltage. A 250 ohm resistor will give a voltage signal of 1 to 5 volts. A 500 ohm resistor will give a voltage signal of 2 to 10 volts.

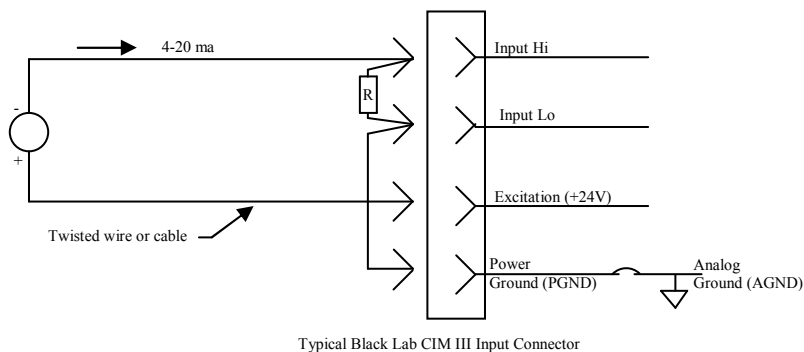

Separately Powered (4-wire) Instruments Using External Power Supply

This type of sensor or transmitter requires an external power supply, typically 24 volts. Any of the Type I, Type II or Type III Connector Interface Modules is suitable for this type of connection.

The power supply is normally connected to the power terminals of the transmitter or sensor. The + **Current Out** terminal of the sensor is connected to the Input Hi terminal of the Connector Interface Connector. The - **Current Out** terminal of the sensor is connected to the Input Lo terminal of the Connector Interface Connector. Remember that the Input Lo terminal also must be connected to the Analog Ground (AGND) terminal. A resistor R is connected across the Input Hi to Input Lo terminals to convert the current into a voltage that the Black Lab can measure. The resistor R should

be chosen to generate a convenient voltage. A 250 ohm resistor will give a voltage signal of 1 to 5 volts. A 500 ohm resistor will give a voltage signal of 2 to 10 volts.

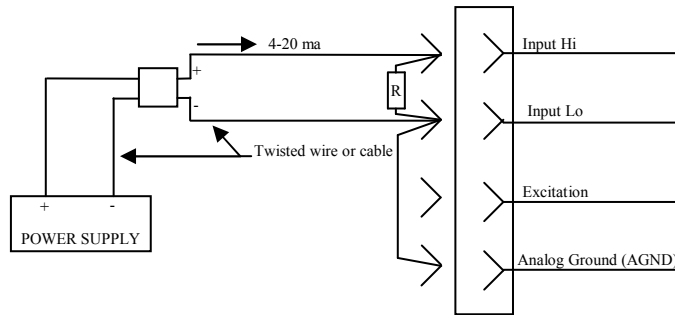

Typical Black Lab Input Connector

Separately Powered (4-wire) Instruments Using Black Lab Power Supply

In order to connect this type of sensor or instrument, the Black Lab must be equipped with the optional 24 volt power supply in the Type III Connector Interface Module. One twisted wire or cable connects from the Black Lab's excitation and power ground terminals to the instrument's power terminals. Another twisted wire or cable connects the instrument's output current terminals to the Black Lab's analog input terminals. The positive (+) output of the instrument connects to the Input Hi terminal and the negative (-) output of the instrument connects to the Input Lo terminal. A resistor R is connected across the Input Hi to Input Lo terminals to convert the current into a voltage that the Black Lab can measure. A jumper is needed between the Input LO and Power Ground terminals to provide a reference to Analog Ground. The resistor R should be chosen to generate a convenient voltage. A 250 ohm resistor will give a voltage signal of 1 to 5 volts. A 500 ohm resistor will give a voltage signal of 2 to 10 volts.

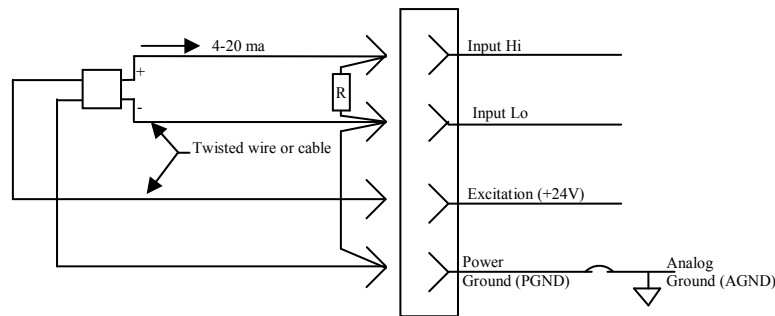

Typical Black Lab CIM III Input Connector