



BLACK LAB SYSTEM  
TECHNICAL NOTE #101

**SUBJECT:** Connecting Analog Sensors to the Black Lab  
See also Bulletin on CIM (Connector Interface Modules) available from Analog Interfaces

**DATE OF LAST REVISION:** 10/18/2005

**REV # 1**

**Analog Input Structure**

The general input structure of an analog input is shown in the figure below. Each of the HI and LOW input lines goes to an input of a differential input, high impedance, programmable gain, instrumentation amplifier. In order to get accurate and reliable measurements, the input signals must be referenced to the circuit's analog common. The following sections show how to connect various types of sensors to achieve the best results. However, since installations vary from place to place, these may not cover all possible situations. Call us if you need help with sensor connections that are not shown here.

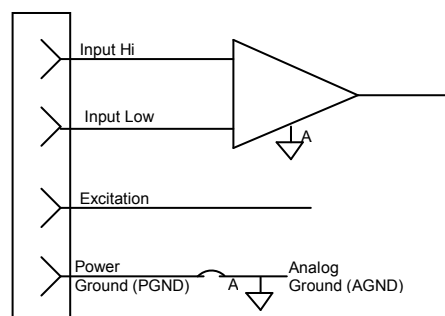

Typical Black Lab Analog Input Circuit

**Floating Signal Source**

This is the most common form of sensor signal. The preferred method to connect signals of this type is to use 2-conductor shielded cable ([Belden 8761](#) for example) as shown in the diagram below. The most positive output of the signal is connected to the HI input terminal and the other one to the LOW input terminal. Since this type of signal does not have any inherent connection to the analog circuit common, a connection must be provided by connecting the analog common terminal to the input LOW terminal. The preferred place to make this connection is at the signal source using the shield of the cable as the conductor.

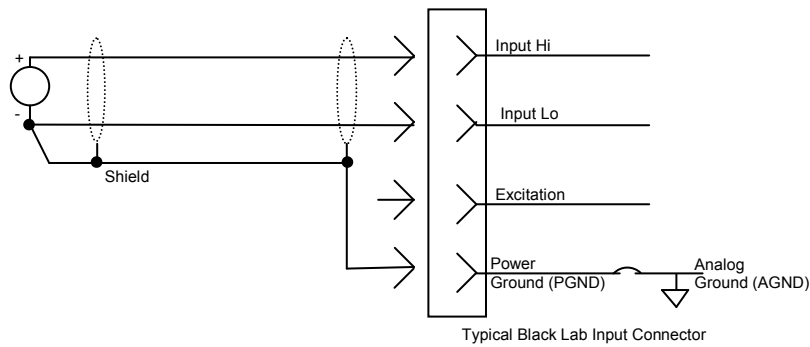

## Grounded Signal Source

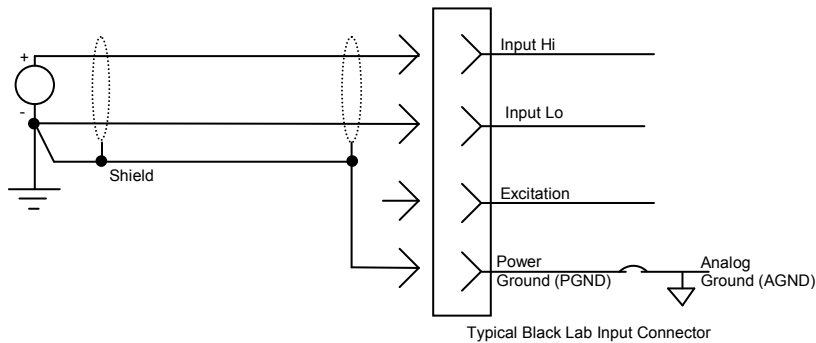

## Multiple Grounded Sensors

When multiple grounded input signals are connected to the Black Lab following the diagram above, it is possible that interference may be generated from ground loops. The way to avoid this is to have the analog common of only one channel connected to the grounded signal source. The remaining channels should leave the shield connection open at the Connector Interface Module and not connect the analog common to the Input Lo.

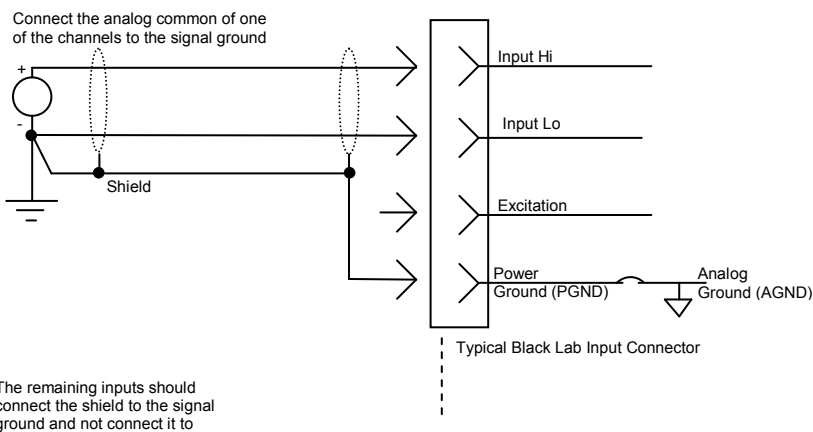

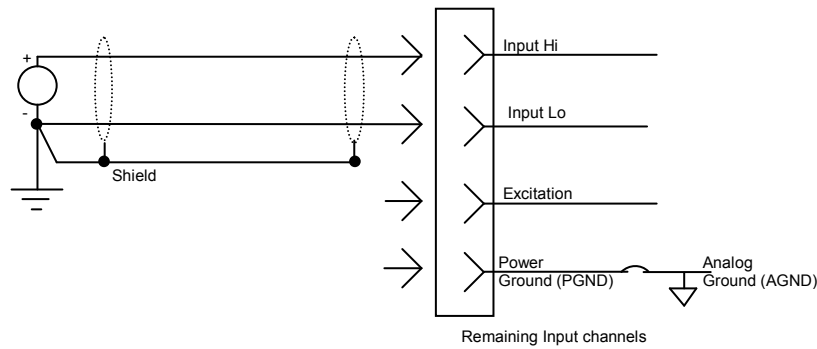

### Ungrounded Thermocouples

Thermocouples are usually connected using 2 conductor, unshielded thermocouple extension wire. For the case of ungrounded thermocouples, the best hook up method is to connect the TC high and low to the Input Hi and Input Lo respectively, as shown in the diagram below. The analog common is then connected to the Input Lo terminal at the Connector Interface Module,

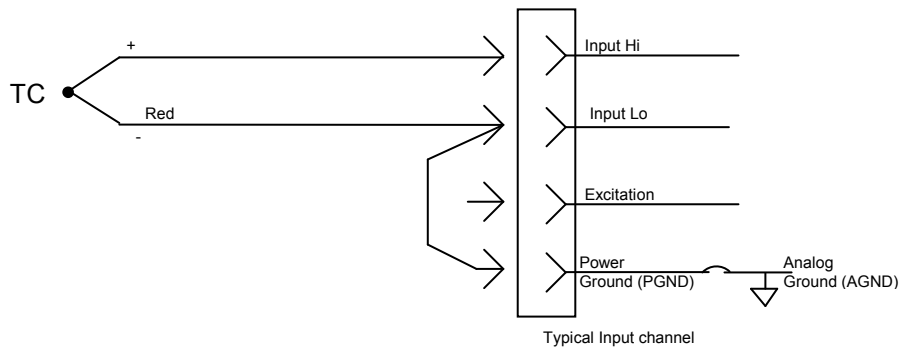

### Grounded Thermocouples

Grounded thermocouples should be connected in the same manner as shown for other grounded sensors above. Only 1 connection should be made from analog common to earth ground. It is best to avoid using grounded thermocouples if at all possible.

### 4-20 ma loop Instruments

Many industrial sensors, signal conditioners, and process transmitters operate with what is called a 4–20 milliamp current loop. This type of sensor has the advantage that it can be located a long distance from the data acquisition system without generating much noise in the connecting cable. These sensors should be connected with twisted pair wire or cable ([Belden 8761](#) or [8740](#) for example).

In order to connect this type of sensor, the Black Lab must be equipped with the optional 24 volt power supply in the Type III Connector Interface Module. One of the wires to the transmitter connects the Excitation terminal to the positive (+) input of the transmitter. The negative (-) terminal of the transmitter is connected to the Input Hi terminal of the CIM III. A resistor R is connected across the Input Hi to Input Lo terminals to convert the current into a voltage that the Black Lab can measure. A jumper between the Input Lo and the analog common returns the current back to the power supply. The resistor R should be chosen to generate a convenient voltage. A 250 ohm resistor will give a voltage signal of 1 to 5 volts. A 500 ohm resistor will give a voltage signal of 2 to 10 volts.

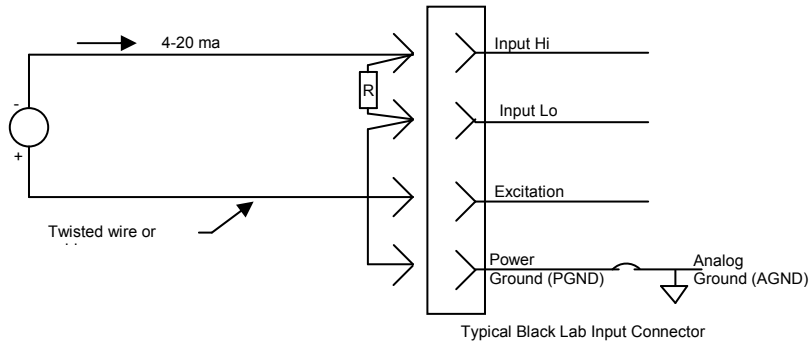

**Strain Gage Sensors**

Another common group or type of transducers, such as pressure transducers, use a strain gage bridge as the sensing element. These sensors should be connected to the Connector Interface Module using 4 conductor shielded cable ([Belden 9940](#) for example) or 2 pair shielded cable ([Belden 8741](#) or [8723](#) for example).

In order to connect to this type of sensor, the Black Lab must be equipped with the optional 1.2 to 10 volt power supply in the Type III Connector Interface Module. The power supply voltage can be adjusted so that the voltage signal coming back from the transducer is proportional to engineering units.

